



Ellicottville Engineering Department

17 Mill St. Ellicottville, New York 14731

Phone: (716) 699-9005



REQUEST FOR PROPOSAL

SPECIFICATIONS AND RELATED DOCUMENTS

SCOPE OF WORK

TO PROVIDE

Valley Village Road Resurfacing & Drainage Improvements Project

FOR

TOWN OF ELLICOTTVILLE, NY

June 23, 2021

All bids for the **Valley Village Project**, for the Ellicottville Engineering Department, according to specifications, shall be received by the Town & Village Engineer, Ben Slotman, P.E. by **Wednesday, July 14, 2021 at 2:00 P.M.** at the Office of the Ellicottville Engineering Department at 17 Mill Street, Ellicottville, NY 14731.

Pre-Construction Meeting: A Pre-Construction Meeting will be held onsite **Friday, July 9, 2021 at 10:00 A.M.** It is recommended that all Bidders attend this meeting.

TABLE OF CONTENTS

Scope of Work	Page #3
Bid Form	Page #7
Required Certifications	
1. Bidders Questionnaire	Page #8
2. Legal Status Information	Page #15
3. Non-Collusive Bidding Certification	Page #16
Agreements / Contract Requirements	Page #17
Attachments (To Be Completed Later)	
1. Notice of Award	
2. Agreement	
3. Notice to Proceed	
4. Certificate of Substantial Completion	
Specifications and Drawings	

Scope of Work

This is a Request for Proposals (RFP) for the resurfacing and installation of drainage on Valley Village Rd in the Town of Ellicottville, New York 14731. The work under this project shall include all work necessary and required to furnish and install approximately 500 LF of drain pipe and drain inlets, milling of pavement approximately 2,000 sf, and resurfacing with HMA approximately 40,600 sf of drive. The resurfacing will include fine grading, furnishing and installing base material, and furnishing and installing top material. Rough grading will be completed by the Town of Ellicottville. The Contractor shall provide all materials, labor, tools, equipment, supervision, permitting, incidentals, and all else necessary or required for a complete and finished project.

The intent of this RFP is to secure a contract with a qualified and competent contractor with experience working in the paving, drainage and site work field.

SHOP DRAWING SUBMITTALS

The Contractor shall be responsible for submitting data on the following items to the Engineer for review and approval:

- Pre-cast Concrete Structures
- SCIPP HDPE Pipe
- Asphalt Binder and Top Mix

REPORTING AND DELIVERABLES

The Contractor shall provide to the Engineer and Owner certified payrolls and OSHA-10 cards for all personnel working on-site through the duration of the project. Additionally, the Contractor shall take clear digital photographs of the work throughout the process in sufficient number to document the work. The digital photographs shall be delivered to the Engineer and Owner as digital files on a USB Drive.

MEASUREMENT AND PAYMENT

- A. Payment under the Lump Sum Bid Item 1 - Mobilization and Permits shall constitute payment in full for all necessary bonds, insurance, permits, other expenses incurred prior to construction, and movement of personnel, equipment, tools, materials, and supplies to and from the project site.
- B. Payment under the Lump Sum Bid Item 2 - Furnish & Install Drainage Improvements shall constitute payment in full for all labor, materials, tools, and equipment necessary and required to complete the work to be paid for under this Item, as described in the Contract Documents, or as further directed by the ENGINEER. Work under this Item shall include, but not be limited to; all necessary and required excavations, to include exploratory and test excavation; all removal and disposal of unusable materials (as directed by the Engineer), to include all transportation of removed materials to be disposed of from the point of removal, to the point of disposal; preparation of all subgrades and subbases, to include grading, backfilling, and compaction; all

necessary and required clearing and grubbing (limits of clearing must be approved by the Engineer prior to the start of this work); all necessary and required temporary restoration (until permanent restoration is completed); all necessary and required survey and stakeout; all handling and cutting of the various required materials; all required pipe, fittings and parts (all sizes); all required precast concrete structures including cast iron frame and grates; all connections to existing pipes; supply and installation of bedding material where required; backfilling and compaction of native material where permitted, supply, installation, and compaction of select backfill material where required; all necessary and required sheeting and/or shoring; all work and materials associated with handling/dealing with existing pipe/channel flows (water); removal and disposal of excess or unsuitable soils; removal and disposal of existing culvert pipe when required; all other work not specifically mentioned or included in other bid items, but necessary and required to provide the drainage system complete, in place, and ready for use.

- C. Payment under the per square foot Bid Item 3 - Asphalt Milling shall constitute payment in full on a per square foot basis for all labor, materials, tools, and equipment necessary and required to complete the work to be paid for under this Item, as described in the Contract Documents, or as further directed by the ENGINEER. Work under this Item shall include, but not be limited to; all necessary and required excavations, to include exploratory and test excavation; all removal and
- D. Payment under the per square foot Bid Item 4 - Asphalt Resurfacing shall constitute payment in full on a per square foot basis for all labor, materials, tools, and equipment necessary and required to complete the work to be paid for under this Item, as described in the Contract Documents, or as further directed by the ENGINEER. Work under this Item shall include, but not be limited to; all preparation of subbase including fine grading; all cleaning required to permit for ideal placement conditions of the asphalt courses; miscellaneous saw-cutting and/or milling; furnish and install all required tack coating; furnish and install (machine install) 3 inches (compacted thickness) of NYSDOT Type 3 asphalt binder course; furnish and install (machine install) 1 inches (compacted thickness) of NYSDOT Type 7 asphalt top course; all other work not specifically mentioned or included in other bid items, but necessary and required to provide the asphalt surface complete, in place, and ready for use. All proposed paving and compaction equipment must be approved by the Engineer prior to the start of any of this work

PROPOSAL FORMAT

The Contractor shall provide all of the costs specifically outlined in this Scope of Work in the attached "Bid Form" as well as any additional costs that will be incurred to complete the work described herein. The Contractor shall also include a Statement of Qualifications detailing their qualifications for performing the specified work and giving references for equivalent work completed in the past. The Contractor shall submit proof of insurance to include Worker's Compensation, Employer's Liability Insurance, Commercial General Liability Insurance, Comprehensive Automobile Liability Insurance, Owner's Protective Liability Insurance, and Umbrella Coverage. New York State Prevailing Wage Rates apply to all work performed under this contract. The Wage Rate Schedule for this project has not been included as part of this RFP, a copy of the Wage Rate Schedule for this project can be requested from the Engineer. The Contractor shall be responsible for complying with any changes to the NYS Prevailing Wage Rate Schedule throughout the project.

Required proof of insurance is required in the following amounts:

1. Worker's Compensation and Disability Benefits with coverage to the statutory limits as required by the laws of the State of New York in sufficient limits to discharge obligations under all applicable state Worker's Compensation laws, and, where applicable, the United States Longshoremen and Harbor Workers Act, the Jones Act and Admiralty or Maritime Law.
2. Employers Liability Insurance, including occupational disease coverage, in the amount of at least \$1,000,000.
3. Commercial General Liability Insurance providing coverage for the Contractor for legal liability and customarily covered expenses for bodily injury and property damage with respect to the Work under this Contract, in the amount of at least \$1,000,000.
4. Comprehensive Automobile Liability insurance in the amount of at least \$1,000,000 Combined Single Limit, and shall include the MCS-980 Sudden and Accidental Pollution endorsement.
5. Owner's Protective Liability insurance providing coverage for the Owner as the named insured for legal liability, in the amount of at least \$1,000,000 Per Occurrence and \$1,000,000 in the Aggregate.
6. Umbrella Coverage/Excess Liability Insurance providing coverage for the Owner and the Contractor for costs in excess of the limits set forth above so that the total aggregate limit of liability under the primary and umbrella policies is not less than \$1,000,000.
7. Owner, Engineer, and all others required, shall be named as additional insured on all previously mentioned insurance policies.
8. Proof of the insurance requirements previously listed shall be submitted to the Engineer for review and approval, prior to the commencement of any work.

A schedule of payments shall also be included with the Contractor's proposal. The Contractor shall hold the prices submitted for a period of 60 days. This work is intended to be completed in the summer of 2021. The Contractor shall provide us with a schedule of the work and estimated completion time at the start of work.

The contract shall be between the Contractor and:

Town of Ellicottville
1 W. Washington Street
P.O. Box 600
Ellicottville, New York 14731

Proposals shall be submitted to the Town of Ellicottville Engineer at:

Mr. Ben Slotman
Town Engineer - Town of Ellicottville
1 W. Washington Street
P.O. Box 600
Ellicottville, New York 14731
Phone: 716-699-9005
Email: ben.slotman@evlengineering.com

Please direct any questions about the Scope of Work to Ben Slotman at
ben.slotman@evlengineering.com.

**ALL PROPOSALS SHALL BE DELIVERED TO THE TOWN OF ELLICOTTVILLE
ENGINEERING DEPARTMENT AT 17 MILL STREET, ELLICOTTVILLE NY ON OR
BEFORE 2:00 PM PREVAILING TIME ON WEDNESDAY, JULY 14, 2021**

Town of Ellicottville
Valley Village Road Resurfacing and Drainage Project

Bid Form

Proposal of _____ (hereinafter called "BIDDER"), organized and existing under the laws of the State of _____ doing business as _____. To Town of Ellicottville (hereinafter called "OWNER").

BIDDER agrees to perform all the work described in the RFP for the following unit or lump sum prices:

NOTE: The Town of Ellicottville is exempt from sales and compensating use taxes of the State of New York and cities and counties of the State of New York on all materials sold to the Owner. These taxes are not to be included in this Bid.

ITEM	DESCRIPTION	UNITS	QUANTITY	UNIT PRICE	TOTAL
1	Mobilization and Permits	LS	1		
2	Furnish and Install Drainage Improvements	LS	1		
3	Asphalt Milling	SF	2,000		
4	Asphalt Resurfacing	SF	40,600		
	TOTAL				

TOTAL AMOUNT OF ALL BID PRICES: \$ _____
(Number)

 (Written)

Respectfully submitted:

 Name of the Contractor Street Address

 Signature City, State, and Zip

 Title Date

 License number (if applicable)

SEAL - (if BID is by a Corporation)

BIDDER'S QUESTIONNAIRE

Town or Ellicottville
Valley Village Road Resurfacing and Drainage Project

Submitted By: _____

Which is:

_____ A Corporation _____ A Co-Partnership _____ An Individual

Principal Office Address:

By filling out this Questionnaire, the Bidder acknowledges that the information contained below is true and accurate.

Part 1 – General Bidder Information

1. How many years has your organization been in business as a contractor under your present business name?

2. How many years of experience in Paving and Drainage Construction work has your organization had:

(a) As a General Contractor _____ (b) as a Sub-Contractor _____

3. What similar projects has your organization completed? (List at least three)

Project: _____

Type of Work: _____

Total Construction Cost: _____

Date of Completion: _____

Project Owner: _____

(provide references and _____

Contact information) _____

Project: _____
Type of Work: _____
Total Construction Cost: _____
Date of Completion: _____
Project Owner: _____
(provide references and
Contact information) _____

Project: _____
Type of Work: _____
Total Construction Cost: _____
Date of Completion: _____
Project Owner: _____
(provide references and
Contact information) _____

Attach additional information with this Questionnaire if necessary.

4. Has your company ever failed to complete any work awarded to you? _____

If so, where and why?

5. Has your company been issued a Notice of Termination on any work awarded to you? _____

If so, where and why?

6. Has any officer or partner of your organization ever failed to complete a construction contract handled in his own name? _____

If so, state name of individual, name of owner and reason thereof.

7. In what other lines of business are you financially interested?

8. For what **corporations or individuals** have you performed work within the last 5 years? (Please provide references)

Project: _____

Type of Work: _____

Total Construction Cost: _____

Date of Completion: _____

Project Owner:
(provide references and
Contact information) _____

Project: _____

Type of Work: _____

Total Construction Cost: _____

Date of Completion: _____

Project Owner:
(provide references and
Contact information) _____

Project: _____

Type of Work: _____

Total Construction Cost: _____

Date of Completion: _____

Project Owner:
(provide references and
Contact information) _____

Attach additional information with this Questionnaire if necessary.

9. For what **towns, villages or cities** have you performed work within the last 5 years? (Please provide references)

Project: _____
Type of Work: _____
Total Construction Cost: _____
Date of Completion: _____
Project Owner:
(provide references and
Contact information) _____

Project: _____
Type of Work: _____
Total Construction Cost: _____
Date of Completion: _____
Project Owner:
(provide references and
Contact information) _____

Project: _____
Type of Work: _____
Total Construction Cost: _____
Date of Completion: _____
Project Owner:
(provide references and
Contact information) _____

Attach additional information with this Questionnaire if necessary.

10. What is the construction experience of the principal individuals of your organization?

Individual's Name: _____
Current Company Position: _____
Years of Construction Experience: _____
Types and Magnitude of work completed: _____

Individual's Name: _____
Current Company Position: _____
Years of Construction Experience: _____
Types and Magnitude of work completed: _____

Individual's Name: _____
Current Company Position: _____
Years of Construction Experience: _____
Types and Magnitude of work completed: _____

Attach additional information with this Questionnaire if necessary.

Part 2 – Project Specific Questions

Question:

Does your organization have adequate personnel and equipment to complete the entirety of this project by September 15, 2021?

Does your organization have experience with Prevailing Rate and Certified Pay Roll

Does your organization carry adequate insurance policies for municipal work?

Does your organization have experience working with drainage pipe and precast concrete structures?

Does your organization have experience with grading, leveling, and survey equipment?

Does your organization have experience installing and compacting hot mix asphalt?

Does your organization have experience locating underground utilities?

Does your organization have properly trained personnel to layout the proposed work?

YES	NO

LEGAL STATUS INFORMATION

To facilitate correct drawing and execution of contract, proposer shall supply full information concerning legal status:

FIRM NAME: _____

PRINCIPAL OFFICE:

Street _____

City, State, Zip _____

Area Code _____ Telephone _____

LOCAL OFFICE:

Street _____

City, State, Zip _____

Area Code _____ Telephone _____

CONTRACT TO BE SENT TO: Principal Office: _____ Local Office: _____

CHECK ONE: Corporation _____ Partnership _____ Individual _____

(Incorporated under the Laws of the State of _____)

(If foreign corporation, state if authorized to do business in the State of New York: Yes _____ No _____ Not Applicable ___)

TRADE NAME: _____

NAMES AND ADDRESSES OF PARTNERS:

_____	_____
_____	_____
_____	_____

NAME, TITLE, AND ADDRESS OF PERSON AUTHORIZED TO SIGN CONTRACT ON BEHALF OF PROPOSER:

Name: _____

Title: _____

Address: _____

PLEASE TYPE OR PRINT

NON-COLLUSIVE BIDDING CERTIFICATION

By submission of this Bid, each Bidder and each person signing on behalf of any Bidder certifies, and in the case of a joint Bid each party thereto certifies as to its own organization, under penalty of perjury, that to the best of knowledge and belief:

- a) The prices in this Bid have been arrived at independently without collusion, consultation, communication, or agreement, for the purpose of restricting competition, as to any matter relating to such prices with any other bidder or with any competitor;
- b) Unless otherwise required by law, the prices which have been quoted in this Bid have not been knowingly disclosed by the Bidder and will not knowingly be disclosed by the Bidder prior to opening, directly or indirectly, to any other Bidder or to any competitor; and
- c) No attempt has been made or will be made by the Bidder to induce any other person, partnership or corporation to submit or not to submit a Bid for the purpose of restricting competition.

Resolved that _____ (Name of Corporation Officer) be authorized to sign and submit the Bid or proposal of this corporation for any or all phases of the following project:

Town of Ellicottville
Valley Village Road Resurfacing and Drainage Project

And to include in such Bid or proposal the certificate as to non-collusion required by Section one hundred three-d of the General Municipal Law as the act and deed of such corporation, and for any inaccuracies or misstatements in such certificate this corporate Bidder shall be liable under the penalties of perjury.

The foregoing is a true and correct copy of the resolution adopted by _____ (Corporation) at a meeting of its Board of Directors held on _____ (Date).

Affix Corporate Seal

Secretary

RESPECTFULLY SUBMITTED,

BY: _____
Name & Address of Bidder

Signature & Title of Authorized Officer

Date

AGREEMENTS / CONTRACT REQUIREMENTS

1. BID DEPOSIT:

For a bid amount of \$10,000 or LESS a certified check for Five Hundred dollars (\$500) must be submitted with the bid. For a bid amount GREATER than \$10,000 a BOND or certified check for five percent (5%) of bid amount must be submitted with the bid. The undersigned agrees that the bid security may be retained by the Town of Ellicottville until contracts have been signed and Performance Bonds have been delivered to the Town of Ellicottville. Should the successful bidder to whom the bid is awarded fail to execute the agreement submitted by the Town of Ellicottville in accordance with the formal bid and other contract documents and to furnish the required performance bond within fourteen (14) calendar days after the notice of award, the certified check or the bid bond amount shall be forfeited to the Town of Ellicottville as liquidated damages caused by such failure.

2. PERFORMANCE BOND.

The successful bidder or bidders shall, within two weeks after notice of the award, enter into a contract with the Town of Ellicottville and furnish a performance bond running to the Town of Ellicottville in the amount of twenty-five percent (25%) of bid amount, which will be retained until completion of the contract. The Performance Bond must be in a format acceptable to the Town of Ellicottville Attorney.

3. BID FORM.

Bid shall be submitted on these Town of Ellicottville bid forms or bid will not be considered. Bid must be typed or printed in ink. Original autograph signatures in ink are required. Facsimile or rubber stamp signatures will not be accepted.

4. CHANGES.

Any change in wording or interlineation by a bidder of the inquiry as published by Town of Ellicottville shall be reason to reject the proposal of such bidder, or in the event that such change in the Invitation to Bid is not discovered prior to entering into a contract, to void any contract entered into pursuant to such bid.

5. INFORMALITIES.

The Town of Ellicottville may consider informal any bid not prepared and submitted in accordance with the provisions hereof & may waive any informalities or reject any and all bids. The contract award will be made to the responsible bidder submitting the lowest acceptable bid. Conditional bids will not be accepted.

6. BID TIME.

Any bid may be withdrawn prior to the above scheduled time for the opening of bids, or authorized postponement thereof. Any bid received after the time specified shall not be considered.

7. INVESTIGATIONS.

The Town of Ellicottville may make such investigations as it deems necessary to determine the ability of the bidder to perform the work, and the bidder shall furnish to the Town of Ellicottville all such information and data for this purpose as the Town of Ellicottville may request. The Town of Ellicottville reserves the right to reject any bid if the evidence submitted by, or investigation of, such bidder fails to satisfy the Town of Ellicottville that such bidder is properly qualified to carry out the obligations of the contract and to complete the work contemplated therein.

8. NON-COLLUSIVE CERTIFICATION.

Non-collusive bidding certification shall be made by each bidder in the form provided and shall be submitted as a part of the bid. Bids submitted without non-collusive bidding certification will be considered irregular and may be rejected by the Town of Ellicottville.

9. CONTRACT AWARD.

Contract(s) or purchase order(s) will be awarded after due consideration of the suitability of goods and/or services bid to satisfy these specifications, the total cost of such goods and/or services including all cost elements, and the timeliness of the agreed upon delivery date.

10. EXECUTORY CLAUSE.

This EXECUTORY CLAUSE shall be a part of any agreement entered into pursuant to this bid: It is understood by the parties that this agreement shall be executory only to the extent of the monies available to the Town of Ellicottville and appropriated therefore, and no liability on account thereof shall be incurred by the Town of Ellicottville beyond the monies available and appropriated for the purpose thereof.

11. PRICES.

Prices shall be quoted F.O.B. destination, delivered inside and installed, or as otherwise specified in the specifications. "Tailgate Delivery" will not be accepted unless specified by the Town of Ellicottville.

12. TRANSPORTATION CHARGES.

Collect transportation charges will not be paid by the Town of Ellicottville. All freight, cartage, rigging, postage or other transportation charges shall be prepaid.

13. TAXES.

No taxes are to be billed to the Town of Ellicottville. Bid shall not include any Federal, State, or local excise, sales, transportation, or other tax unless Federal or State law specifically levies such tax on purchases made by a political subdivision. Any applicable taxes from which the Town of Ellicottville is not exempt shall be listed separately as cost elements, and added into the total net bid.

14. COMPLIANCE WITH LAWS.

The successful bidder shall comply with all laws, rules, regulations and ordinances of the Federal Government, the State of New York and any other political subdivision or regulatory body which may apply to its performance under this contract.

HAZARD COMMUNICATION In complying with the above laws, rules and regulations, and pursuant to 12 NYCRR part 820 and Section 876 of the Labor Law, it is the responsibility of the Town of Ellicottville to provide the successful bidder with the following information:

- (a) The material safety data sheets (MSDS) for any hazardous chemicals to which employees may be exposed will be made available.
- (b) The telephone numbers of plant personnel who are to be contacted in the event of a chemical spill or accident and
- (c) emergency procedures in the event of a fire or spill.

MATERIAL SAFETY DATA SHEETS. The successful bidder shall be responsible for the provision of the MSDSs to the Town of Ellicottville prior to introducing hazardous materials onto the site, insuring compliance before work is started and disseminating any information to the Town of Ellicottville employees concerning significant chemical hazards that the successful bidder is bringing to the Town of Ellicottville 's workplace. the MSDSs will be obtained from the successful bidder for all hazardous materials prior to bringing the materials on the site. these MSDSs will be maintained be the Town of Ellicottville as long as those materials are present. It is the responsibility of the successful bidder to train its own employees.

15. CONTRACT ASSIGNMENTS.

The bidder shall not assign, transfer, sublet, or otherwise dispose of this contract, or of its right, title or interest in the contract, or its power to execute the same, to any other person or corporation without the previous consent, in writing, of the Town of Ellicottville Supervisor.

16. CASH DISCOUNT.

ANY CASH DISCOUNT which is a part of a bid will be considered as a reduction in the bid prices in determining the award of the bid. Date of invoice must not precede date of delivery. The Town of Ellicottville policy is to pay all claims in a timely manner within the specified time. However, if for some reason payment is delayed, the Town of Ellicottville will take the discount when payment is made. If this is unsatisfactory, please quote net. The Town of Ellicottville will not pay any interest charges.

17. ALTERNATE ITEMS.

If material or services other than those specified in this bid document are offered, the bidder must so state and furnish at the time of bid opening, if so requested, and as part of his bid the following information in duplicate:

- (a) Complete description of the item offered, and detailed explanation of the differences between the item specified and the item offered. If, in the opinion of the Department Head, sufficient detail is not presented as a part of the sealed bid to permit definite evaluation of any substitute item, the bid will not be considered.
- (b) Descriptive literature of item offered, for evaluation.
- (c) List of installations in Town of Ellicottville of the item offered.
- (d) List of other installations.

18. ADDITIONAL INFORMATION.

Any additional information which bidder desires to add to the bid shall be written on a separate sheet of paper, attached to and submitted with the formal sealed bid, to be read at the formal opening.

19. WORKMANSHIP.

Workmanship must meet with the approval of the department head or heads involved, and shall be first class in every respect without exception and shall be equal to the best modern practices. Materials furnished are to be new and unused. All materials furnished or work performed are to be guaranteed free from defects. Anything found defective or not meeting specifications, no matter in what state of completion, may be rejected and shall be made good by the contractor at his own expense.

20. HOLD HARMLESS.

The successful bidder to whom the bid is awarded shall indemnify and hold harmless Town of Ellicottville and its agents and employees from and against all claims, damages, losses or causes of action arising out of or resulting from such vendor's performance pursuant to this bid.

21. BID VALIDITY.

This bid is firm and irrevocable for a period of 45 days from the date and time of the bid opening. If a contract is not awarded within the 60 day period, a bidder to whom the bid has not been awarded, may withdraw his bid by serving written notice of his intention to do so upon the Clerk of the Town of Ellicottville. Upon withdrawal of the bid pursuant to this paragraph, the Town of Ellicottville will forthwith return the bidder's security deposit.

22. CONTRACT INTEREST.

No official, or employee of the Town of Ellicottville, who is authorized in such capacity, and on behalf of the Town of Ellicottville, to negotiate, make, accept or approve or to take part in negotiating, making, accepting, or approving this contract shall become directly or indirectly interested personally in this contract or in any part hereof. No officer or employee of, or for the Town of Ellicottville, who is authorized in such capacity, and on behalf of the Town of Ellicottville, to exercise any supervisory, administrative, or other function, in connection with this contract, shall become directly or indirectly interested personally in this contract or in any part hereof.

23. OTHER CUSTOMERS.

Prices charged to Town of Ellicottville are to be no higher than those offered to any other governmental or commercial consumer. If a bidder has a New York State or a Federal GSA

contract for any of the items covered in this bid or any similar items, he shall so indicate that he has said contract on these bid papers and supply a copy of this contract within 5 days if so requested by the Town of Ellicottville.

24. PRICE IS FIRM.

The unit prices bid shall remain firm, and any other charges bid shall also remain firm, for delivery of the equipment, material, work, or services described in this bid. No cost increase shall be charged for any reason whatsoever.

25. BIDDER AFFIRMATION.

In executing this bid, the bidder affirms that all of the requirements of the specifications are understood and accepted by the bidder, and that the prices quoted include all required materials and services. The undersigned has checked all of the bid figures, and understands that the Town of Ellicottville will not be responsible for any errors or omissions on the part of the undersigned in preparing this bid. Mistakes or errors in the estimates, calculations, or preparation of the bid shall not be grounds for the withdrawal or correction of the bid or bid security. In case of error in extension of prices in the bid, the unit price will govern.

26. CALCULATION OF PURCHASE PRICE

When calculating the purchase price, list on the individual bid forms the TOTAL cost of each unit.

27. INSURANCE

The (Contractor, Vendor, Etc.) shall secure and maintain, at its own cost and expense, insurance coverage complying with Classification "(selected on form)", with insurance companies licensed in the State of New York. The Town of Ellicottville must be named as an additional insured for purposes of coverage, but not for payment of premium. The (Contractor, Vendor, Etc.) shall file a certificate of insurance with the Town of Ellicottville covering all acts performed by the (Contractor, Vendor, Etc.) prior to performing pursuant to this Agreement or receiving any payment thereunder and shall be responsible for updating the certificate as necessary throughout the term of the Agreement. All certificates of insurance shall provide that Town of Ellicottville be given thirty (30) days' notice prior to non-renewal or cancellation of these policies. **Certificate of Insurance shall be furnished by the bidder within five (5) days of the "Intent to Award" and prior to signing of contract.** Failure to supply a satisfactory certificate within five (5) days after the "Intent to Award" may result in the cancellation of award and for the forfeiture of the Contractor's bid security, in the sole discretion of the Town of Ellicottville.

Notice of Award

Project:	21002 Valley Village	Owner:	Town of Ellicottville
----------	----------------------	--------	-----------------------

Contract:	Valley Village Road Resurfacing and Drainage Project
-----------	--

Bidder:

Bidder's Address:

The OWNER has considered your BID dated _____, submitted by you in response to its Advertisement for Bids and the Instructions To Bidders, for the above described WORK.

You are hereby notified that your BID has been accepted for the Contract Price of \$_____.

You are required by the Instructions for Bidders to execute the Agreement, and to furnish the required Bonds and Certificate(s) of Insurance within ten (10) days from the date of this Notice (noted at top).

If you fail to execute said Agreement, and to furnish said Bonds and Certificate(s) of Insurance within ten (10) days from the date of this Notice, said OWNER will be entitled to consider all your rights arising out of the OWNER's acceptance of your BID as abandoned, and may annul the Notice of Award, and consider forfeiture of your Bid Security. The OWNER will be entitled to such other rights as may be granted by law.

You are required to return an acknowledged copy of this Notice of Award to the OWNER.

Dated this the _____ day of _____, 2021.

Village of Ellicottville

By Ben Slotman, PE

Title Town and Village Engineer – Ellicottville, NY



ACCEPTANCE OF NOTICE:

Contractor

By: _____
Authorized Signature

Title

Date

Notice To Proceed

Project:	21002 – Valley Village	Owner:	Town of Ellicottville
Contract:	Valley Village Road Resurfacing and Drainage Project		
Bidder:			
Bidder's Address:			

You are notified that the Contract Times under the above contract will commence to run on July, 2021. On or before that date, you are to start performing your obligations under the Contract Documents. In accordance with the Bid Sheet, the final date for submission of Shop Drawings is _____ and the date of delivery of the finished project shall be within XX consecutive days after approval of the shop drawings.

You are required to return an acknowledged copy of this Notice of Award to the OWNER.

Dated this the _____ day of _____, 2021.

Town of Ellicottville

By Ben Slotman, PE

Title Town and Village Engineer – Ellicottville, NY



ACCEPTANCE OF NOTICE:

_____ Contractor

By: _____ Authorized Signature

_____ Title

_____ Date



Ellicottville Engineering Department

17 Mill St. Ellicottville, New York 14731

Phone: (716) 699-9005



AGREEMENT BETWEEN TOWN OF ELLICOTTVILLE AND CONTRACTOR FOR CONSTRUCTION CONTRACT

THIS AGREEMENT is by and between _____ Town of Ellicottville _____ (Owner)

and _____ (Contractor).

Owner and Contractor, in consideration of the mutual covenants set forth herein, agree as follows:

ARTICLE 1 - WORK

1.01 Contractor shall complete all Work as specified or indicated in the Contract Documents. The Work is generally described as follows:

The work under this project shall include all work necessary and required to furnish and install approximately 500 LF of drain pipe and drain inlets, milling of pavement approximately 2,000 sf, and resurfacing with HMA approximately 40,600 sf of drive. The resurfacing will include fine grading, furnishing and installing base material, and furnishing and installing top material. Rough grading will be completed by the Town of Ellicottville.

1.02 Contractor shall complete all other work, not necessarily described in the Contract Documents, but as may be directed by the Owner, to be included as part of the Work, to included but not limited to, all work authorized by Change Order(s), and all other Work determined by the Owner to be necessary and required, as directed by the Owner.

ARTICLE 2 - THE PROJECT

2.01 The Project for which the Work under the Contract Documents may be the whole or only a part is generally described as follows:

Town of Ellicottville
Valley Village Road Resurfacing and Drainage Project

ARTICLE 3 - CONTRACT TIMES

3.01 The Work will be substantially completed by September 15, 2021, and completed and ready for final payment by September 30, 2021.

3.02 Liquidated Damages

A. Contractor and Owner recognize that time is of the essence of this Agreement and that Owner will suffer financial loss if the Work is not substantially completed within the times specified in Paragraph 3.01 above, plus any extensions thereof agreed to. Failure to complete work and make delivery of materials within the stated time period shall result in a notification to the Contractor and the beginning of a 5 Working Day Grace

Period. Failure to deliver with the Grace Period will result in a penalty of 1% of the Contract Price on a per day basis from the date of notification and/or cancellation of Contract.

ARTICLE 4 - CONTRACT PRICE

4.01 Owner shall pay Contractor for completion of the Work in accordance with the Contract Documents an amount in current funds equal to the sum of the amounts determined pursuant to Paragraph 4.01.A. All specific cash allowances are included in the prices and have been computed in accordance with the Contract Documents

- A. The CONTRACTOR agrees to perform all of the WORK described in the CONTRACT DOCUMENTS and comply with the terms therein for the sum of \$ _____, or as shown in the Bid Sheet.**
- B. CONTRACTOR shall submit a voucher and invoice for payment to the Owner on a monthly basis in a form acceptable to the Town Engineer based on an acceptable payment schedule provided by the CONTRACTOR for the time period of the contract.**

ARTICLE 5 – CONTRACTOR’S REPRESENTATIONS

5.01 In order to induce Owner to enter into this Agreement Contractor makes the following representations:

- A. Contractor has examined and carefully studied the Contract Documents and the other related data identified in the Bidding Documents.
- B. Contractor has visited the Site and become familiar with and is satisfied as to the general, local, and Site conditions that may affect cost, progress, and performance of the Work.
- C. Contractor is familiar with and is satisfied as to all federal, state, and local Laws and Regulations that may affect cost, progress, and performance of the Work.
- D. Contractor has carefully studied all available or known reports of explorations and tests of subsurface conditions at or contiguous to the Site and all drawings of physical conditions in or relating to existing surface or subsurface structures at or contiguous to the Site (except Underground Facilities).
- E. Contractor has obtained and carefully studied (or assumes responsibility for doing so) all additional or supplementary examinations, investigations, explorations, tests, studies, and data concerning conditions (surface, subsurface, and Underground Facilities) at or contiguous to the Site which may affect cost, progress, or performance of the Work or which relate to any aspect of the means, methods, techniques, sequences, and procedures of construction to be employed by Contractor, including any specific means, methods, techniques, sequences, and procedures of construction expressly required by the Bidding Documents, and safety precautions and programs incident thereto.
- F. Contractor does not consider that any further examinations, investigations, explorations, tests, studies, or data are necessary for the performance of the Work at the Contract Price, within the Contract Times, and in accordance with the other terms and conditions of the Contract Documents.
- G. Contractor is aware of the general nature of work to be performed by Owner and others at the Site that relates to the Work as indicated in the Contract Documents.
- H. Contractor has correlated the information known to Contractor, information and observations obtained from visits to the Site, reports and drawings identified in the Contract Documents, and all additional examinations, investigations, explorations, tests, studies, and data with the Contract Documents.

- I. Contractor has given Engineer written notice of all conflicts, errors, ambiguities, or discrepancies that Contractor has discovered in the Contract Documents, and the written resolution thereof by Engineer is acceptable to Contractor.
- J. The Contract Documents are generally sufficient to indicate and convey understanding of all terms and conditions for performance and furnishing of the Work.

ARTICLE 6 – CONTRACT DOCUMENTS

6.01 Contents

- A. The Contract Documents consist of the following:
 - 1. This Agreement
 - 2. The Request for Proposal
 - 3. Contractors Bid
 - 4. Site Plan
 - 5. Details/Sections

ARTICLE 7 - MISCELLANEOUS

7.01 Assignment of Contract

- A. The CONTRACTOR shall not assign, transfer, convey, or otherwise dispose of this Contract, or any portion thereof, or of its right, title, or interest therein, or its power to execute such Contract, to any other person or corporation without the previous consent in writing of the OWNER.
- B. The provisions of this Section shall not hinder, prevent, or affect an assignment by the CONTRACTOR for the benefit of creditors made pursuant to law, nor is it intended to prohibit subcontracting a portion of the Work of the Contract in accordance with the provisions of the law, and this Contract.

7.02 Successors and Assigns

- A. Owner and Contractor each binds itself, its partners, successors, assigns, and legal representatives to the other party hereto, its partners, successors, assigns, and legal representatives in respect to all covenants, agreements, and obligations contained in the Contract Documents.

7.03 Severability

- A. Any provision or part of the Contract Documents held to be void or unenforceable under any Law or Regulation shall be deemed stricken, and all remaining provisions shall continue to be valid and binding upon Owner and Contractor, who agree that the Contract Documents shall be reformed to replace such stricken provision or part thereof with a valid and enforceable provision that comes as close as possible to expressing the intention of the stricken provision.

IN WITNESS WHEREOF, Owner and Contractor have signed this Agreement. One counterpart each has been delivered to Owner, Contractor, Town Engineer. All portions of the Contract Documents have been signed, initialed, or identified by Owner and Contractor or identified by the Town Engineer on their behalf.

This Agreement will be effective _____ which is the Effective Date of the Agreement. This Agreement shall not be effective unless and until Agency's designated representative concurs.

OWNER:

Town of Ellicottville
P.O. Box 600
Ellicottville, New York 14731

CONTRACTOR:

By: _____

Title: Town Supervisor

[CORPORATE SEAL]

Attest: _____

Title: _____

Designated Representatives:

Name: Ben Slotman, P.E.

Title: Town Engineer

Address for giving notices:

P.O. Box 600

17 Mill Street

Ellicottville, NY 14731

Phone: (716) 699-9005 FAX: _____

(If Owner is a corporation, attach evidence of authority to sign. If Owner is a public body, attach evidence of authority to sign and resolution or other documents authorizing execution of Owner-Contractor Agreement.)

By: _____

Title: _____

[CORPORATE SEAL]

Attest: _____

Title: _____

Designated Representatives:

Name: _____

Title: _____

Address for giving notices:

Phone: _____ FAX: _____

License No.: _____
(Where applicable)

Agent for service or process: _____

(If Contractor is a corporation or a partnership, attach evidence of authority to sign.)



CERTIFICATE OF SUBSTANTIAL COMPLETION

DATE OF ISSUANCE: _____

OWNER: _____

CONTRACTOR: _____

Contract: _____

Project: _____

OWNER's Contract No. _____ ENGINEER's Contract No. _____

- This Certification of Substantial Completion applies to **all Work** under the Contract Documents.
 This Certification of Substantial Completion **applies to the following specified parts** of the Contract Documents:

The Work to which this Certificate applies has been inspected by authorized representatives of the OWNER, CONTRACTOR and ENGINEER, and found to be substantially complete and is also the date of commencement of applicable warranties required by the Contract Documents, * (except as attached.)

The Work is hereby declared to be substantially complete with the Contract Documents on:

Date of Substantial Completion

A "Punch-List" of items to be completed or corrected is attached hereto. This list may not be all-inclusive, and the failure to include an item in it does not alter the responsibility of the CONTRACTOR to complete all Work in accordance with the Contract Documents. The items in the tentative list shall be completed or corrected by the CONTRACTOR within _____ days of the above date of Substantial Completion.

Liquidated Damages Assessed in the Amount of: \$_____ based on contract completion date and agreed upon amount in the original project advertisement.

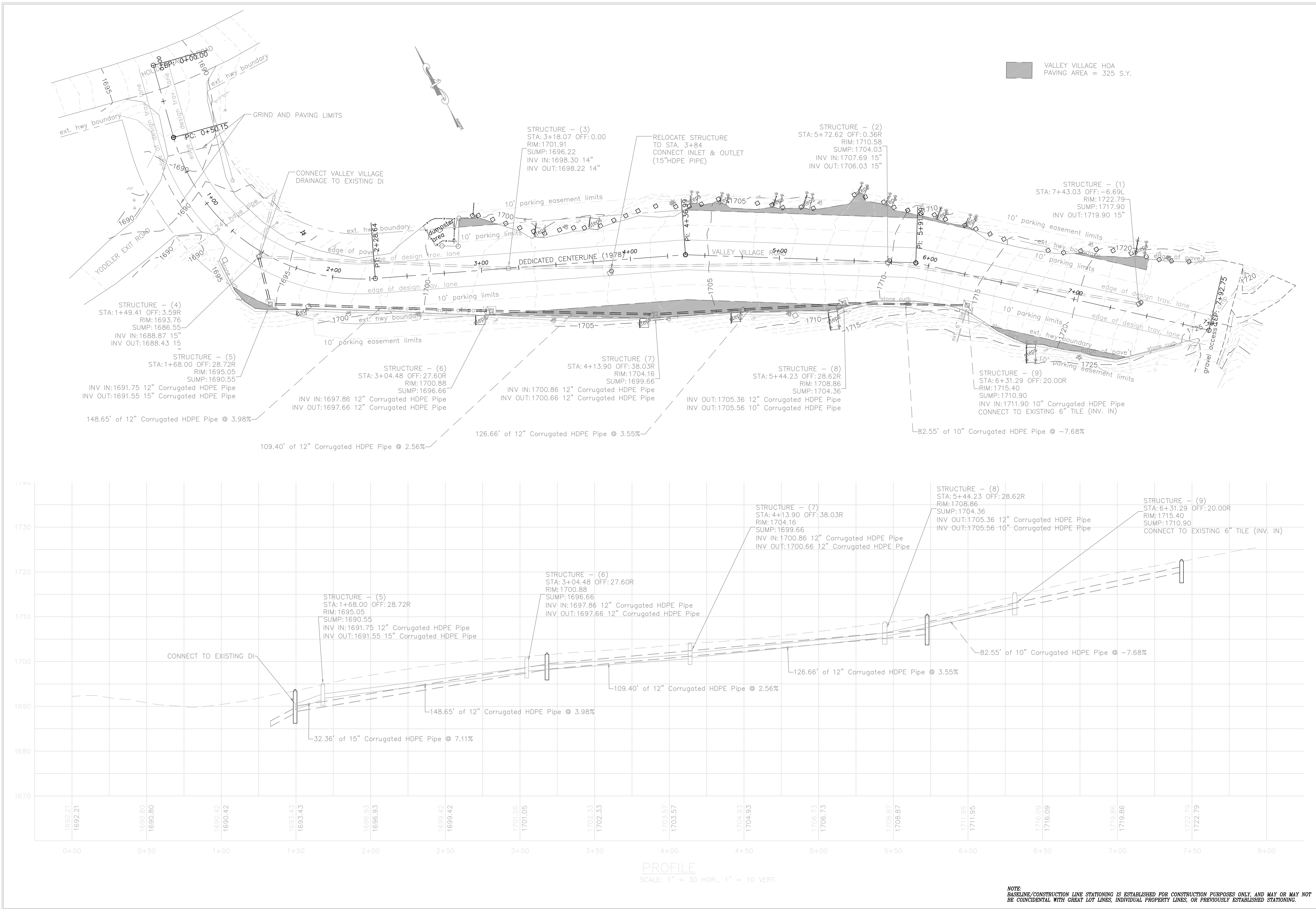

© CATTARAUGUS COUNTY 2017

SURVEY #		DATE	
BK.	LOT	REV.	DATE

SCALE: 1" = 30.0'

UNAUTHORIZED ALTERATION OR ADDITION TO THIS DOCUMENT IS A VIOLATION OF SECTION 7209 OF THE NEW YORK STATE EDUCATION LAW
 CAD DRAWING: DO NOT EDIT MANUALLY

CATTARAUGUS COUNTY
 DEPARTMENT OF PUBLIC WORKS
 8810 NYS ROUTE 242
 LITTLE VALLEY, NEW YORK 14755
 716-938-9121

HOA DRAINAGE PLAN VIEW & PROFILE
 TOWN OF ELIJACOTTVILLE
 VALLEY VILLAGE ROAD
 HOLIDAY VALLEY ROAD AND VALLEY VILLAGE ROAD INTERSECTION

SHEET 1 OF 2

PROJECT NO.
 H.XXXX.XXX

NOTE: BASELINE/CONSTRUCTION LINE STATIONING IS ESTABLISHED FOR CONSTRUCTION PURPOSES ONLY, AND MAY OR MAY NOT BE COINCIDENTAL WITH GREAT LOT LINES, INDIVIDUAL PROPERTY LINES, OR PREVIOUSLY ESTABLISHED STATIONING.

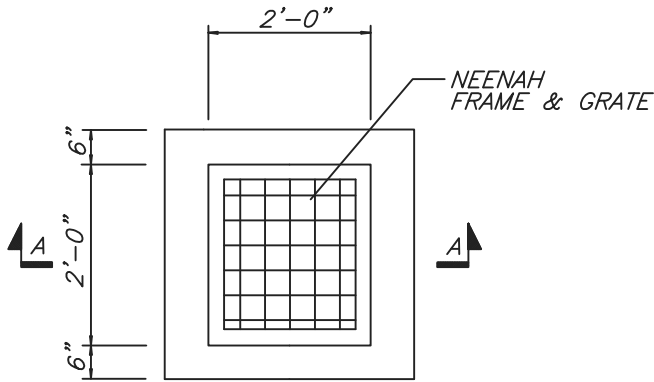

GENERAL NOTES

1. CONCRETE SHALL BE 4000 PSI @ 28 DAYS WITH 5%-9% AIR ENTRAINMENT.
2. STEEL REINFORCING SHALL BE GRADE 60 AND MEET ASTM STANDARDS.
3. CATCH BASIN SHALL MEET OR EXCEED AASHTO HS-20 LOADING.
4. ALL KNOCKOUTS SHALL HAVE A 2"-2-1/2" THICKNESS AND A 1" DIAMETER WEEP HOLE.
5. GRATES SHALL BE MANUFACTURED BY NEENAH FOUNDRY & BE CAST IRON BICYCLE PROOF GRATES. THE STEEL FRAME SHALL BE RECESSED INTO THE TOP OF CATCH BASIN. GRATE AND FRAME SHALL BE FLUSH WITH THE CONCRETE.
6. CATCH BASIN SHALL BE KISTNER CONCRETE 24" SQUARE INSIDE DIMENSION CATCH BASIN OR APPROVED EQUAL.

STANDARDS

1. NYS DOT SPECIFICATIONS

MANUFACTURER

1. NEENAH FOUNDRY
2. KISTNER CONCRETE

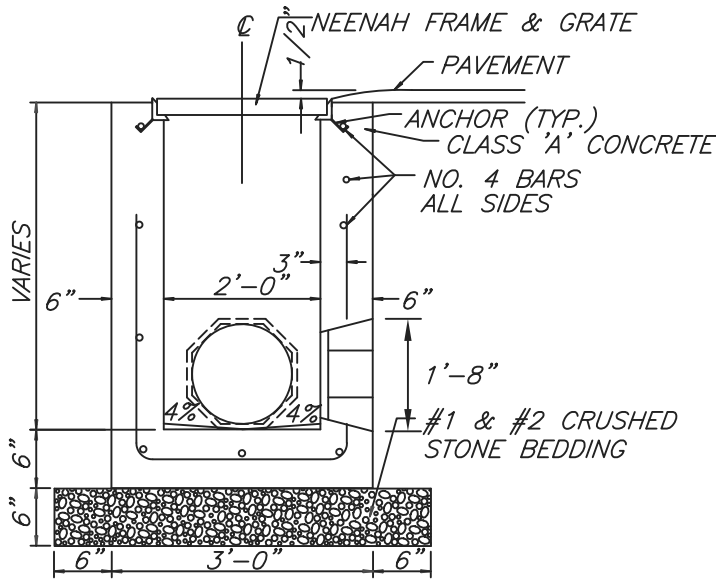

SECTION A-A

STANDARD CATCH BASIN DETAIL

N.T.S.

ISSUE DATE: SEPTEMBER 2018

TOWN & VILLAGE OF ELLICOTTVILLE

REVISIONS	DATE	COMMENTS

EVL ENG DEPT.

STORM - ST-01



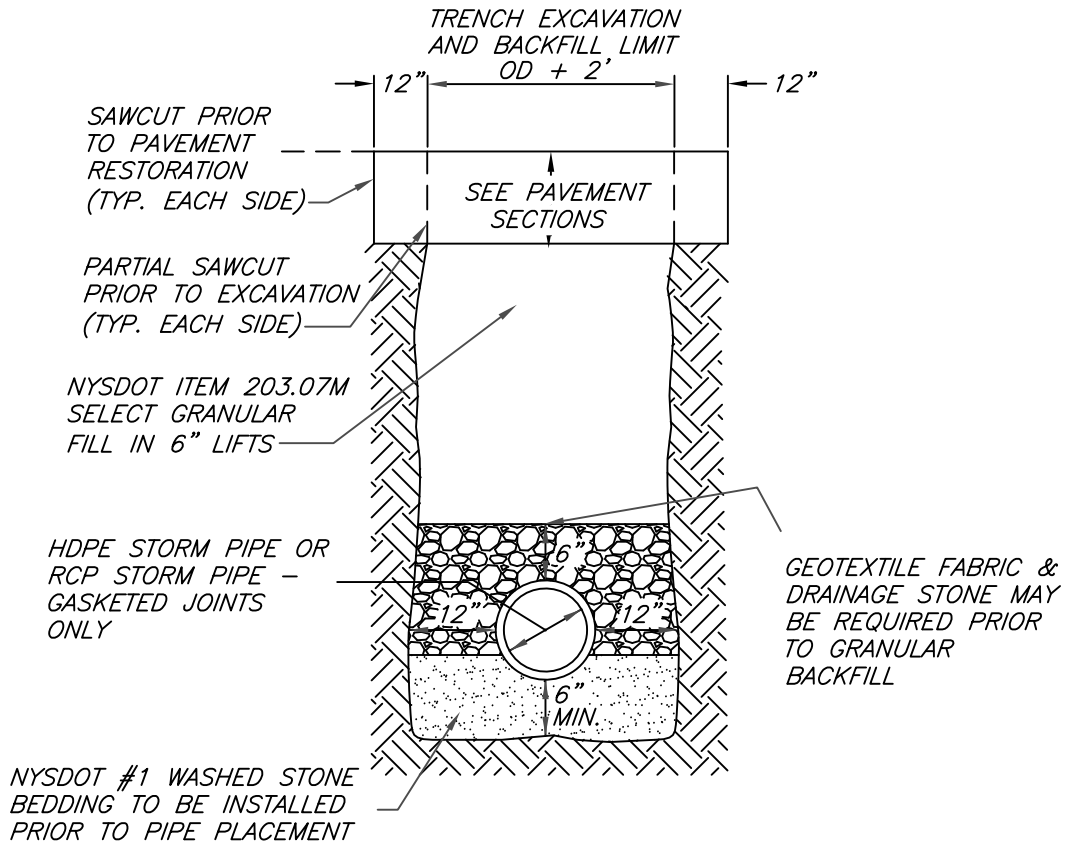

GENERAL NOTES

1. DETERMINATION OF STORMWATER CONVEYANCE PIPE TYPE AND SIZE SHALL BE MADE BY TOWN/VILLAGE ENGINEER.
2. HDPE PIPE SHALL BE SMOOTH INTERIOR, DUAL WALL, CORRUGATED - GASKETED JOINTS.
3. MINIMUM 18" OF COVER.

STANDARDS

1. AASHTO M294
2. ASTM F2306
3. ASTM C76
4. ASTM C507

MANUFACTURER

1. ADS - HDPE STORM PIPE

STORM SEWER TRENCH & PIPE DETAIL

N.T.S.

ISSUE DATE: SEPTEMBER 2018

TOWN & VILLAGE OF ELLICOTTVILLE

REVISIONS	DATE	COMMENTS

EVL ENG DEPT.

STORM -ST-02



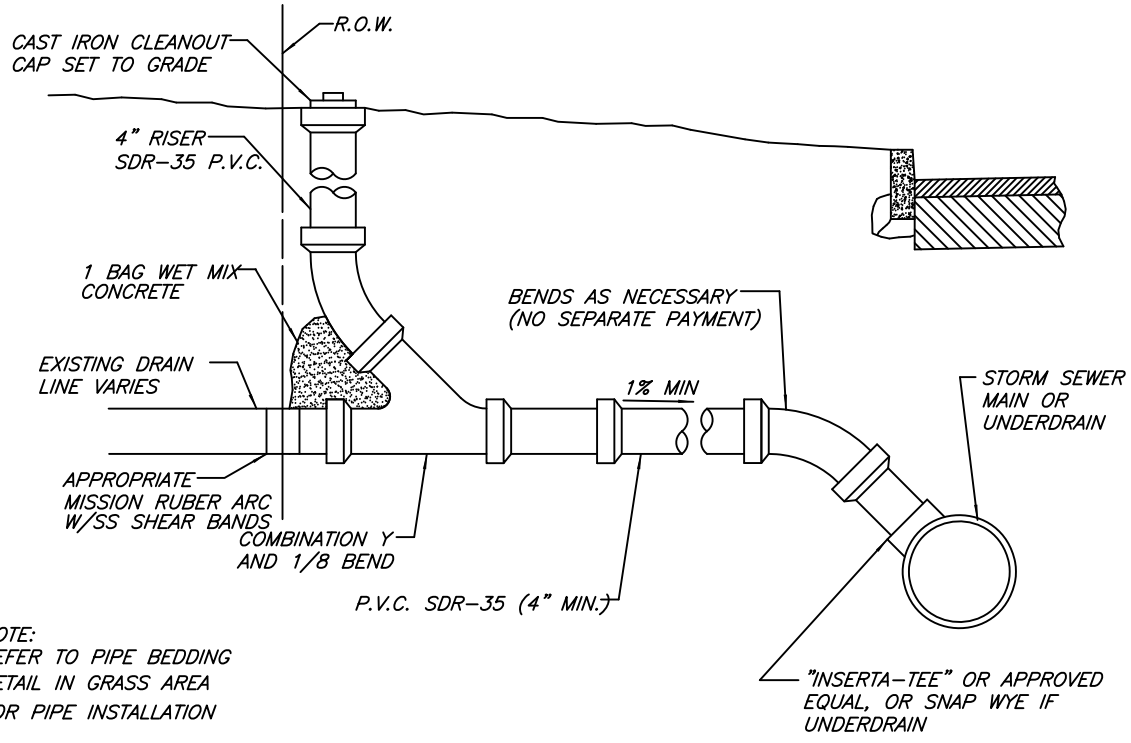

NOTE:
REFER TO PIPE BEDDING
DETAIL IN GRASS AREA
FOR PIPE INSTALLATION

STORM DRAIN LINE CONNECTION
N.T.S.

ISSUE DATE: SEPTEMBER 2018			TOWN & VILLAGE OF ELLICOTTVILLE	
REVISIONS	DATE	COMMENTS	EVL ENG DEPT.	
			STORM -ST-03	
				

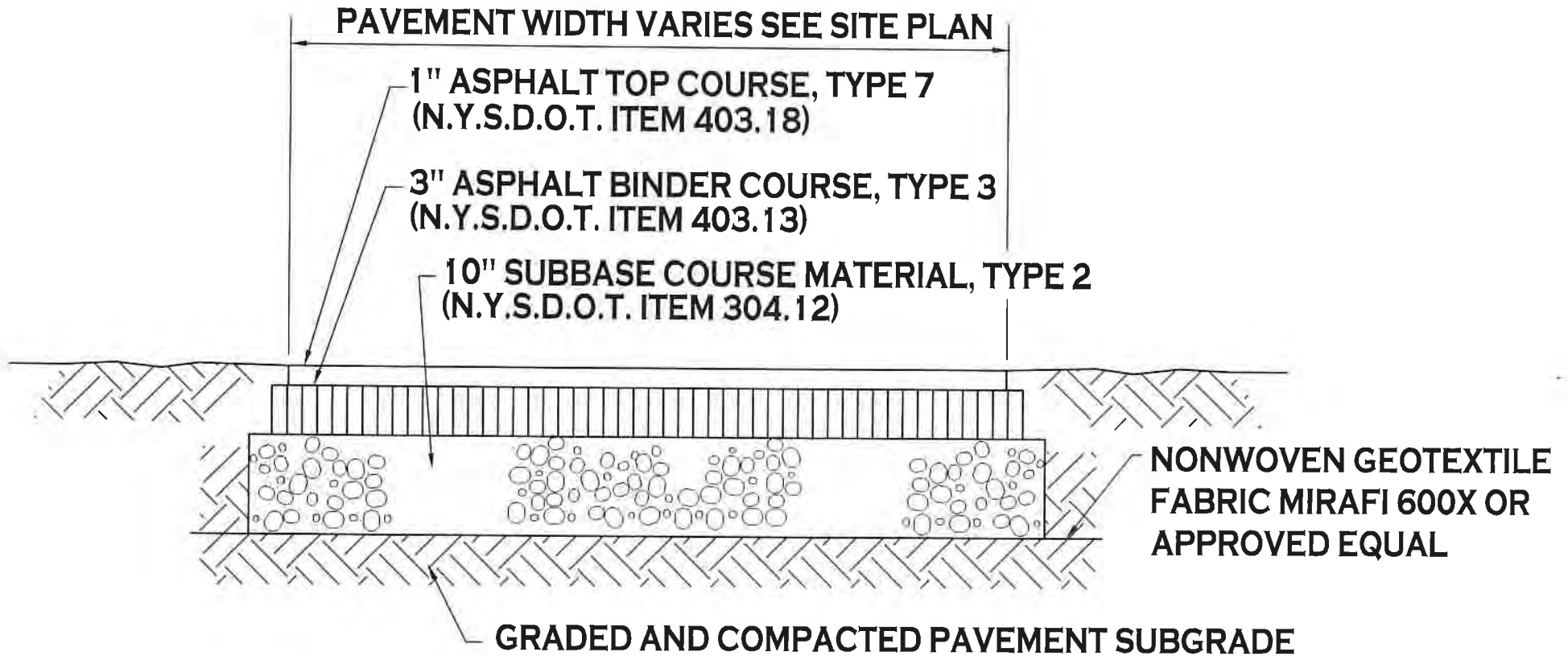

NOTE: CONSTRUCTION METHODS FOR ASPHALT PAVEMENT SHALL CONFORM TO NYSDOT STANDARD SPECIFICATION 401-3, WITH SUBBASE CONSTRUCTION METHODS CONFORMING TO NYSDOT STANDARD SPECIFICATION 304-3.

STANDARD DUTY ASPHALT SECTION

NOT TO SCALE